

March 1993

## Continuously Variable Slope Delta-Demodulator (CVSD)

**NOT RECOMMENDED  
FOR NEW DESIGNS**

### Features

- All Digital
- Requires Few External Parts
- Low Power Drain: 1.5mW from Single 3V to 6V Supply
- Time Constants Determined by Clock Frequency; No Calibration or Drift Problems; Automatic Offset Adjustment
- Filter Reset by Digital Control
- Automatic Overload Recovery
- Automatic "Quiet" Pattern Generation

### Applications

- Voice Decoder for Digital Systems and Speech Syntheses
- Voicemail
- Audio Manipulations; Delay Lines, Echo Generation/Suppression, Special Effects, etc.
- Pagers/Satellites

### Description

The HC-55536 is a CMOS integrated circuit used to convert serial NRZ digital data to an analog (voice) signal. Conversion is by delta demodulation, using the Continuously Variable Slope (CVSD) method of demodulation.

While signals are compatible with other CVSD circuits, the internal design is unique. The analog loop filters have been replaced by digital filters which use very low power and require no external timing components. This digital approach allows inclusion of many desirable features, which otherwise would be difficult to implement. The device is usable from 9Kbits/s to above 64Kbits/s, and may be easily configured with the HC-55564 CVSD for a complete transmit/receive voice channel.

### Ordering Information

PART NUMBER	TEMP. RANGE (°C)	PACKAGE	PKG. NO.
HC1-55536-5	0 to 75	14 Ld CERDIP	
HC1-55536-9	-40 to 85	14 Ld CERDIP	
HC3-55536-5	0 to 75	14 Ld PDIP	
HC3-55536-9	-40 to 85	14 Ld PDIP	

### Pinout

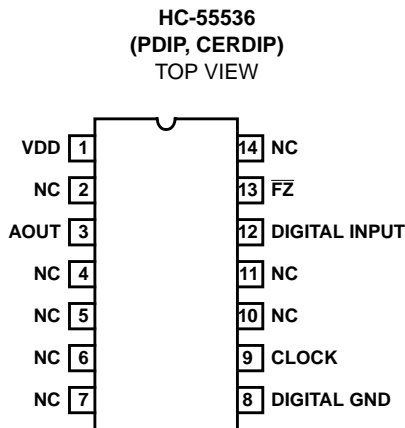

### Functional Diagram

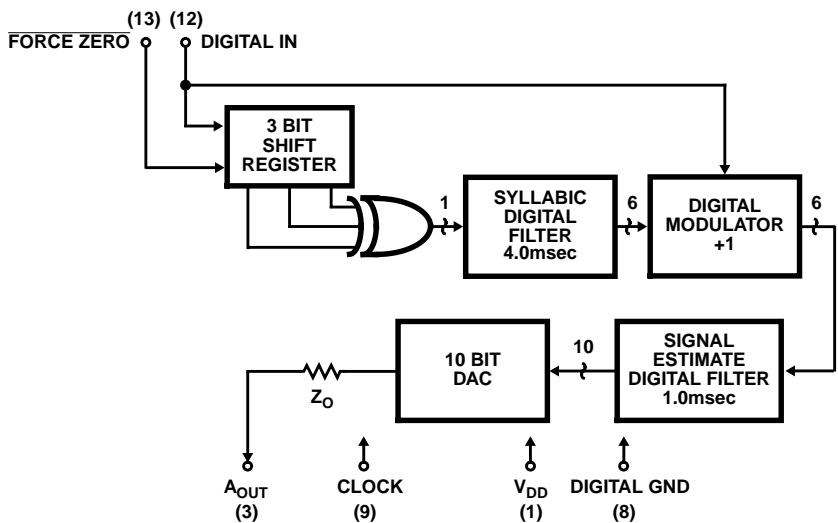

This datasheet has been downloaded from:

[www.DatasheetCatalog.com](http://www.DatasheetCatalog.com)

Datasheets for electronic components.